

Alignna®

Automated Laser Beam Alignment and Stabilization System

- fully automated high precision beam alignment
- self learning parameter settings
- modular system, control of up to 4 beams, all wavelengths
- 2D and 4D scanning (position X,Y, angle X,Y)

Applications



- High precision material processing
- Compensation of drifts and air fluctuations
- Compensation of disturbance by moved optical components (Delay Lines, Tuning Elements, Zoom Optics,...)
- Switching of one laser between several applications
- Multi-dim scans for characterization of optical setups
- Automatic coupling / optimization to single-mode fibers or to High Harmonic Generation Capillaries
- Complete auto-alignment after laser replacement
- Laser / experiment at different optical tables or rooms
- Trepanning Optics: Compensation of laser drifts

Principle of Operation

Laser beams, used in an experiment or in industrial applications, can move in space for many reasons:

1: thermal drifts inside the laser, movements by frequency detuning, by power variation, etc.

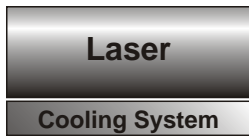

2: thermal drifts of cooling system and mechanical laser mounts

6: moved optical elements (delay lines, switching mirrors, motorized telescopes,...)

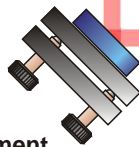
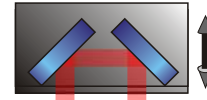

3: drifts of alignment and folding mirror holders

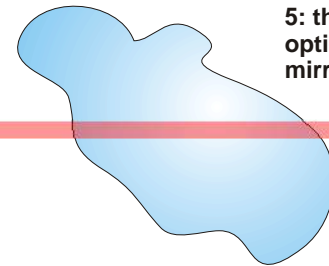

4: air fluctuations and temperature gradients

5: thermal effects in optical elements and mirrors



7: Movement of the experimental (optical) tables or vacuum chambers

- cw and pulsed lasers: rep rate 0.1 Hz ... 200 MHz / cw
- modular system, up to 4 beams controlled by one device
- servo loop accuracy: $< 1 \mu\text{m}$, $< 1 \mu\text{rad}$ (down to 10 ... 100 nm)*
- very large scan range: $> 18^\circ$ ***
- all wavelengths (with standard detectors: 380 ... 1100 nm, with special detectors 180 nm ... 10 μm , even THz), any beam diameter
- high speed: up to 5 kHz servo bandwidth**
- several combinations of motorized and piezo-driven actors
- fully computer control (USB, serial, Ethernet) and fully autarkic operation
- connection of external measurement devices (power meters, PDs, ...)

* with "OneInch" piezo actors

** with "OneInch" piezo actors, small mirrors

*** with motorized mirror mounts "Aligna 40"



PSD 4D e:

Position Sensitive Detector 4D:
Position X,Y, Angle X,Y

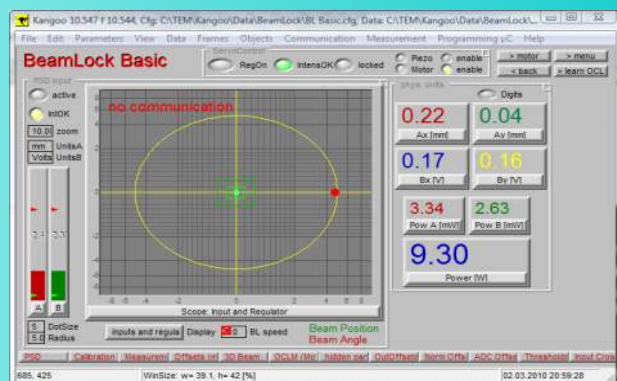

Visualization and Control System

- logging of pointing and power
- several beams simultaneously
- automatic learning of opto-mech setup

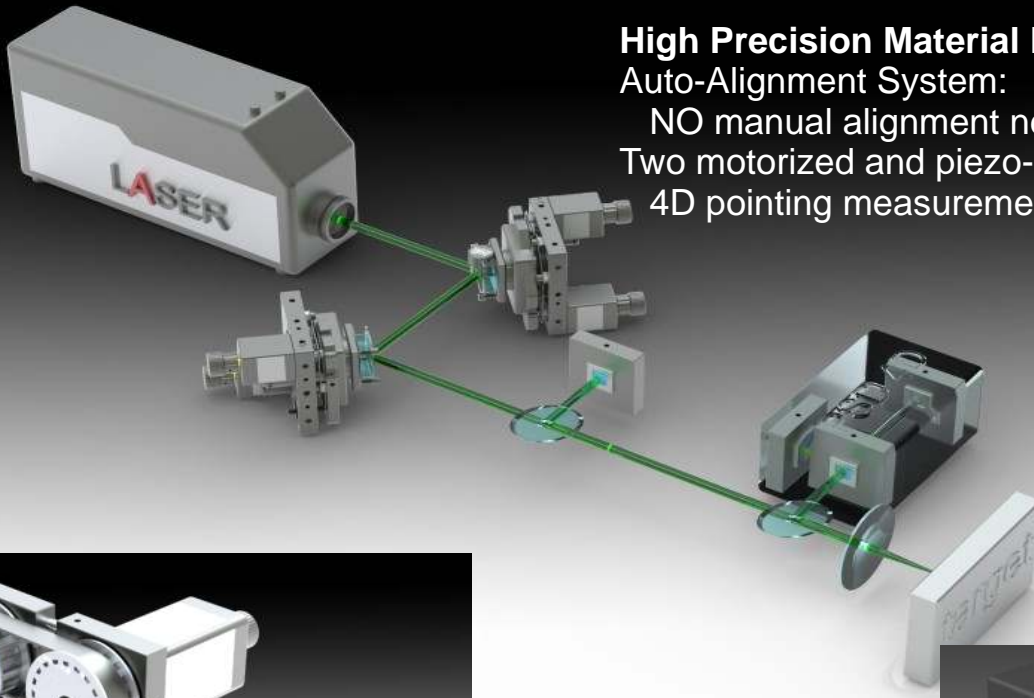

High Precision Material Processing Auto-Alignment System:
NO manual alignment necessary!
Two motorized and piezo-based mirrors,
4D pointing measurement

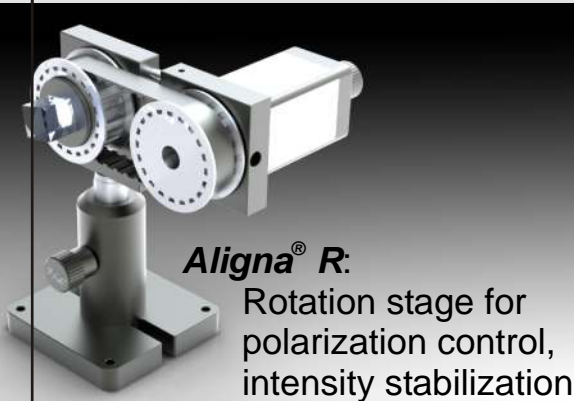

Alignna® R:
Rotation stage for polarization control, intensity stabilization

Alignna® multiDrill:
AutoFocus and Pointing Stabilizer Head

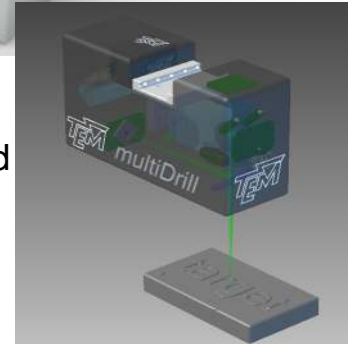

One laser distributed to several high precision applications:
compensation of laser drifts, mechanical drifts, air fluctuations, vibrations, residual position error of switching mirrors

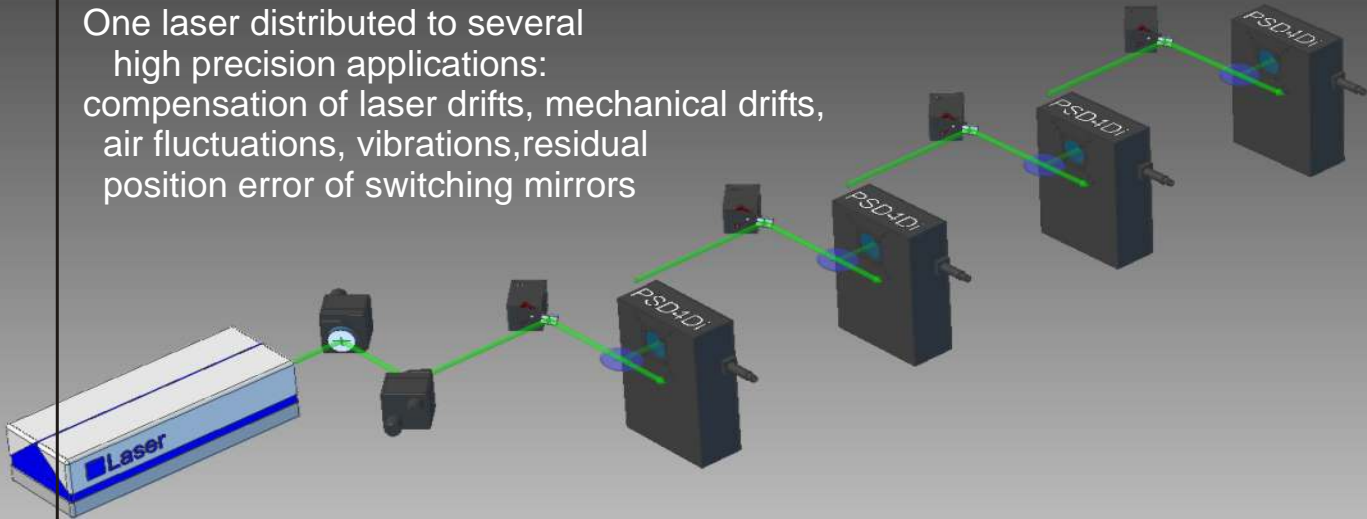

Alignna® StabBoxx:
Compact All-In-One Laser Beam Stabilizer:
4D beam control by two motorized and piezo-based actuators
4D pointing measurement for pointing servo control

very easy integration into existing setups

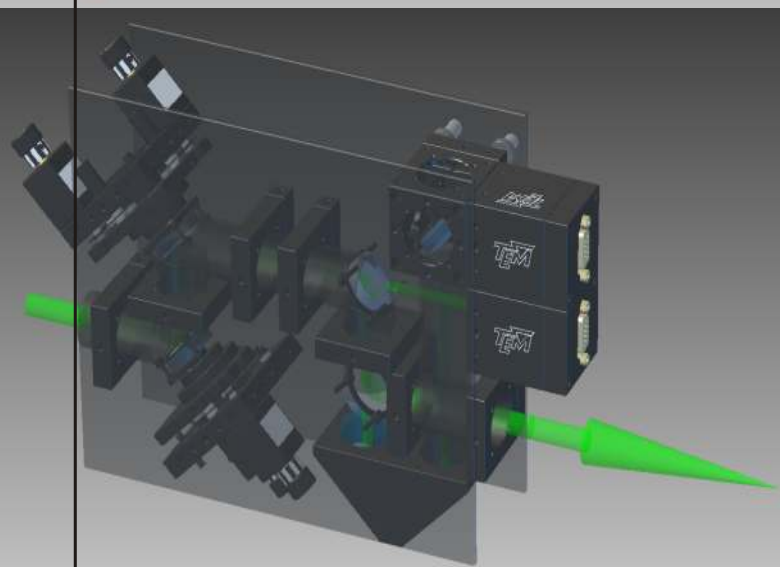

Modular System: Electronic Components

Aligna®

Aligna® 4D: 19" Rack Control Electronics

- modular system: up to 4 independent control modules, 4 beams (4 SPM modules)
- μ Controller 32 bit, interfaces: USB, Serial, (Ethernet opt.)
- LCD menu user guidance, user-definable keys
- Software package for visualization and PC control
- Supply for motor-driven and piezo-based actuators (up to 24 piezo actors, up to 8 motors, up to 16 loads)



SPM: Signal Processing Plug-In Module

- for connection of one PSD 4D, two PSD 2D, or other measurement heads (power meters, photo diodes, temperature, ...)

SPM-P: Add-on to SPM, for use of Piezo Servos

- including four fast servos for piezo actuators (or AOM scanner)
- μ C-controlled state variable filters for compensation of piezo resonances

SPM-SH: Add-on to SPM, for use of Slow-RepRate Pulsed Lasers

- Sample&Hold / Mixing circuitry, incl. pulse signal normalization
- repetition rates: 0.1 Hz ... 30 kHz (>30 kHz: no SPM-SH needed)

SPM-ADDA: Signal Processing Plug-In Module for external devices

- for additional analog and digital inputs and outputs
- input signals from power meter heads, photo diodes, temperature sensors
- output signals to shutters, external devices, control systems
- 8 analog inputs (+/- 10 Volts), 8 analog outputs (+/- 10 Volts), 8 TTL I/O

PiezoDriver: Piezo Actor Driver Module

- eight (max. 12) piezo-based actors (4 x "OneInch", e.g.) per module
- 0...150 V, 50 mA standard (0...95V, 0...500 V,... on demand)

μ Stp Driver: Micro Stepping Driver Module

- including 8 power amplifiers, each 1 A max
- four motorized linear actors (or micro-stepping motors)
2x *Aligna40* or *Aligna60*, e.g.,
or 4x *AlignaLin* or other (std. or microstepping) motors
- other loads, like peltier coolers (TEC), relays, shutters, diode lasers

Aligna IO: Digital IO for communication with SPS, PLC (or other control systems)

- used for status, error, station control
- LEDs for indication of all input/output levels
- standard SUB-D 25 (female) connector
- 4 (6, 8) opto-coupled inputs (TTL compatible, 0...24V, voltage/current)
- 4 (6, 8) relay-coupled outputs (complete galvanic de-coupling, 0.5A max.)
alternatively 4 (6,8) FET outputs

Aligna Con: BNC Connection Box for analog or digital signals

- used for access to all relevant analog input/output signals (PSDs, motors, piezo actors, control signals, TEC, shutter, user-spec. components)
- for use with ext. control systems (oscilloscope, DACS,...)
- 8 BNC connectors, HD15 male, HD15 female

Kangoo: Comprehensive Control Program

- visualization of pointing, intensity, servo, etc.
- logging of pointing, intensity, etc. vs. time
- 2D or 4D scanning and measurement
- self learning algorithms to optimize parameters for best fitting to the opto-mechanical setup, including all kinds of optical elements
- compatible to Windows 7, Vista, XP, 2k, 9x

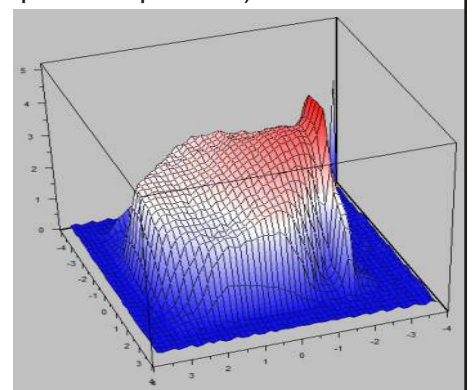

Modular System: Opto-Mechanical Components

Alignna®

- PSD 4D i:** Position Sensitive Detector "industrial"
- 4D measurement of position X,Y and angle X,Y
 - cw and pulsed lasers
 - (test beam pow. cw: 100 μ W...10 mW, pulsed: >10 nJ)
 - high accuracy: < 1 μ m, < 1 μ rad

- PSD 4D e:** Position Sensitive Detector "experimental"
- like "PSD 4D i", but discrete components
 - can be easily adapted to experimental setup or to even higher accuracy: < 10 nm, < 10 nrad

- PSD 2D:** Position Sensitive Detector 2D (cw or pulsed)
- individual use, or combined for 4D detection
 - std. wavelength: 380...1100nm
 - special versions 180 nm...2600 nm

- Aligna 40:** Motorized Mirror Mount 40x40 mm
- two ultra microstepping linear actors
 - manual actuation by knurled knobs
 - reference optical encoder for both axes
 - several fixing methods for mirrors (or other components) (1", 1/2", 2", and others, any thickness)

- Aligna 60:** Motorized Mirror Mount 60x60 mm
- same as *Aligna 40*, larger size, preferred for 2" mirrors)

- Aligna MoPiA 40:** Motorized + Piezo Actors
- compact combination of *Aligna 40* and *BeamScan OneInch*

- Aligna Lin:** Motorized Linear Stage
- application: auto-focussing optics
 - linear travel: 7 mm (more on demand)
 - various adapters for optical components
 - 1" lenses or other components
 - M9x0.5 mm objectives (and others)
 - optical reference pos. detection

- BeamScan OneInch:** Piezo-based XY scanner
- 1.25 mrad, max. 1.5 kHz
 - fitting to standard 1" mirror mounts

- BeamScan HS:** Piezo XY scanner with high stroke
- for auto-coupling to Single-Mode Fibers
 - high stroke: up to 2x100 mrad, 0.5 kHz
 - opt: man. or motorized focussing for SM fibers

- BeamSwitch DC:** Beam Switch and Shutter
- Precision beam switch, double ball bearings, adjustable limits
 - feedback signal (optical encoder) for valid action in both positions
 - beam diameter < 10 mm, beam dump or high reflecting mirror
 - no heat dissipation in both positions (current pulse control)

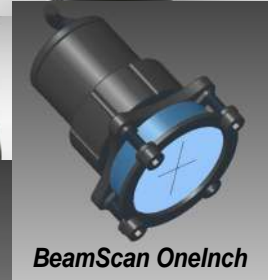
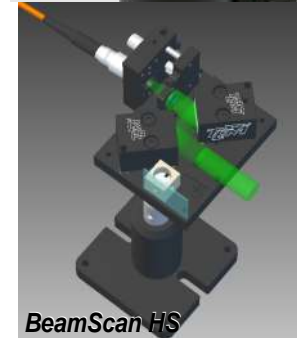
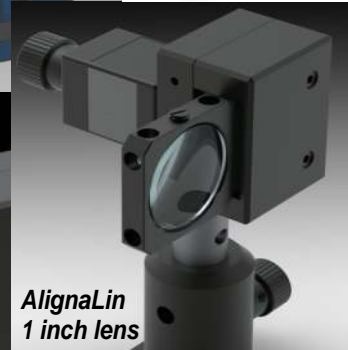
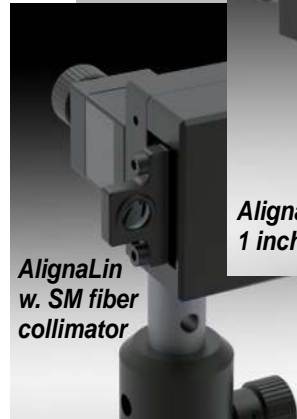
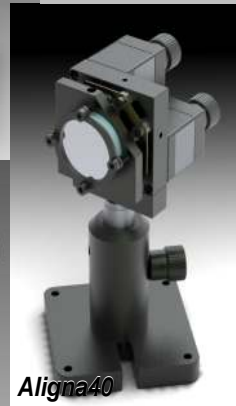
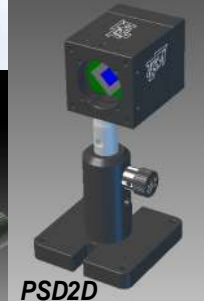
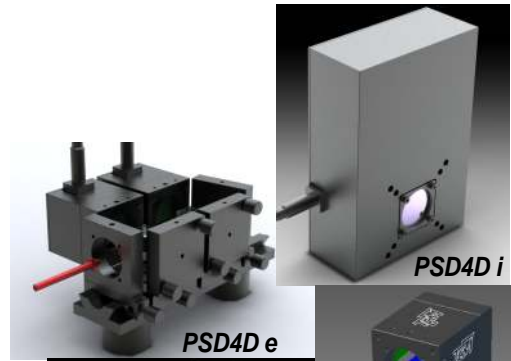

Dimensions:

control electronics in 19-rack	484 x 343 x 150 mm
Aligna40 motorized mirror mount	40 x 40 x 63 mm
Aligna60 motorized mirror mount	60 x 60 x 63 mm
PSD4Di:	100 x 147 x 47 mm
PSD4De:	200 x 110 x 60 mm

Interfaces:
protocol:

USB, RS232 serial, (Ethernet optional)
clear text ASCII commands, internal script language
including visualization and measurement software
incl. user-spec .adaptations, LabView VIs available

Aligna® Control Unit

µC:	32 Bit MC68332
Electrical supply:	100...120/200..250 VAC, 50/60 Hz (24V DC opt.)
Power consumption:	< 97 W (72 W typ.)

Servo bandwidth (4D):	selectable, 0.1 Hz...20 kHz
Number of calculation modules:	1 to 4 (up to 8 PSD2D or 4 PSD4D)
Number of piezo amplifier modules:	1 or 2 (8 ... 24 HV channels)
Number of motor driver modules:	1 or 2 (2 to 4 microstepping motors/actuators)
Output voltage of piezo amps:	std: 0...150 V, active limitation (0..500V, 0..95 V opt.)

Subject to change without notice

Development, Manufacturing and Distribution



03/2011

TEM Messtechnik GmbH
Grosser Hillen 38
30559 Hannover (Germany)

tel +49 (0)511 51 08 96 -30
fax +49 (0)511 51 08 96 -38
info@TEM-Messtechnik.de

www.TEM-Messtechnik.de

